

FULL MORTISE TEMPLATE BUTT HINGES

Sizes: 5 x 4, 5 x 4½, 5 x 5, 5 x 7 and 5 x 8"

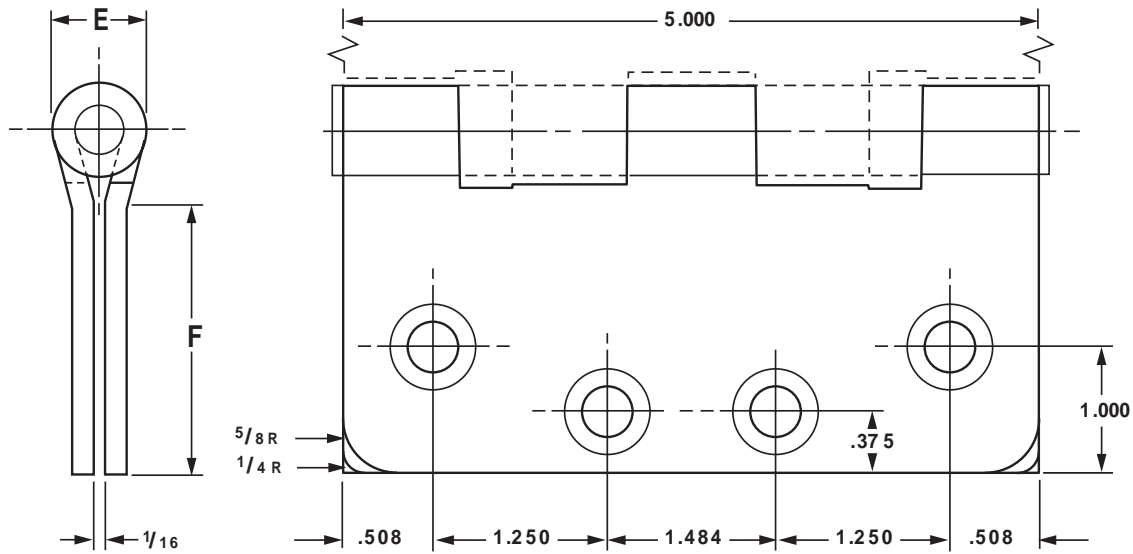

DO NOT SCALE

CLASS NUMBER		Gauge of Metal	(E) Outside Diameter	DISTANCE FROM EDGE OF LEAF TO SWAGE LINE (F)				
Steel Hinges	Nonferrous Hinges			5 x 4	5 x 4½	5 x 5	5 x 7	5 x 8
F179	F191	0.146	0.661	1 5/8	1 13/16	2 1/16	3 1/16	3 9/16
1900	1960	0.146	0.580	1 5/8	1 3/4	2	—	—
1900R	1960R	0.146	0.661	1 5/8	1 13/16	2 1/16	3 1/16	3 9/16
CB179	CB191	0.146	0.669	1 5/8	1 13/16	2 1/16	3 1/16	3 9/16
FBB179	FBB191	0.146	0.669	1 5/8	1 13/16	2 1/16	3 1/16	3 9/16
CB1900	CB1960	0.146	0.580	1 5/8	1 55/64	2 7/64	—	—
CB1900R	CB1960R	0.146	0.669	1 5/8	1 13/16	2 1/16	3 1/16	3 9/16
CB168	CB199	0.190	0.748	1 15/32	1 23/32	1 31/32	2 31/32	3 15/32
FBB168	FBB199	0.190	0.748	1 15/32	1 23/32	1 31/32	2 31/32	3 15/32
IHTCB168	IHTCB199	0.190	0.748	—	1 23/32	—	—	—
CB1901	CB1961	0.190	0.715	—	1 13/16	—	—	—
CB1901R	CB1961R	0.190	0.748	1 15/32	2 23/32	1 31/32	2 31/32	3 15/32
IHTCB1901	IHTCB1961	0.190	0.715	—	1 13/16	—	—	—
IHTCB1901R	IHTCB1961R	0.190	0.748	—	1 23/32	—	—	—

Template hinges of the hospital type conform to above screw hole location.

Hospital type hinges are designated by prefix "HT" to class number.

Also available "RD" radius corners (1/4 or 5/8).

Machine Screw Size — ½ x 12-24 F.H.

Wood Screw Size — [1¼ x No. 12 F.H. for regular weight (0.146) hinges

[1½ x No. 12 F.H. for extra heavy weight (0.190) hinges

NOTE: Prefix IHT indicates Institutional Hinge.

This template conforms with ANSI standard A156.7.